

# IES-3082GP

► **Industrial 10-port managed Ethernet switch with 8x10/100Base-T(X) and 2x100/1000Base-X, SFP socket**

## Features

- Fastest Redundant Ethernet Ring: **O-Ring** (recovery time < 10ms over 250 units of connection)
- **Open-Ring** supports the other vendor's ring technology in open architecture
- **O-RSTP** supports applications with complex topology
- MSTP/RSTP/STP(IEEE 802.1s/w/D)
- Supports **PTP Client** (Precision Time Protocol) clock synchronization
- IGMP v2/v3 (IGMP snooping support) for filtering multicast traffic
- Port Trunking for easy bandwidth management
- SNMP v1/v2c/v3 support for secured network management
- RMON for traffic monitoring
- Event notification through Syslog, Email, SNMP trap, and Relay Output
- Windows utility (**Open-Vision**) supports centralized management and configuration by Web-based, Telnet, and Console (CLI)
- Supports two SFP slots for 100/1000Base-X SFP Fiber
- Rigid IP-30 housing design
- DIN-Rail and wall mounting enabled
- Supports LLDP Protocol



## Introduction

IES-3082GP is managed Redundant Ring Ethernet switch with 8x10/100Base-T(X) and 2x100/1000Base-X SFP ports. With complete support of Ethernet Redundancy protocol, O-Ring (recovery time < 10ms over 250 units of connection), Open-Ring, O-RSTP and MSTP/RSTP/STP (IEEE 802.1s/w/D) can protect your mission-critical applications from network interruptions or temporary malfunctions with its fast recovery technology. IES-3082GP can be managed centralized and convenient by a powerful windows utility — Open-Vision. In addition, the wide operating temperature range from -40°C to 70°C can satisfy most of operating environment. Therefore, the switch is one of the most reliable choices for highly-managed and Fiber Ethernet application.

## Open-Vision

ORing's switches are intelligent switches. Being different from other traditional redundant switches, ORing provides a set of Windows utility (**Open-Vision**) for users to manage and monitor all of industrial Ethernet switches on the industrial network.

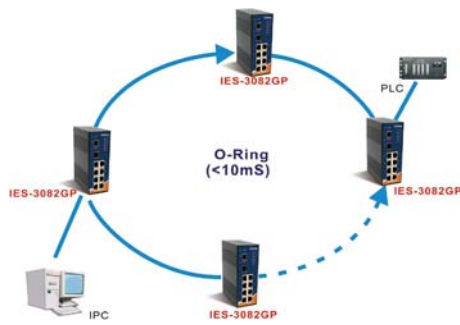

Network connection

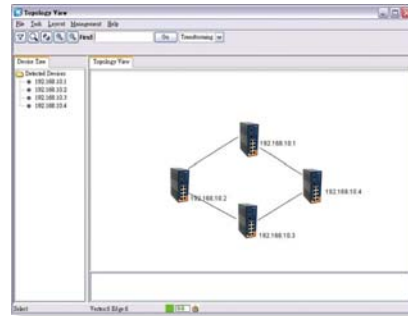

Topology View

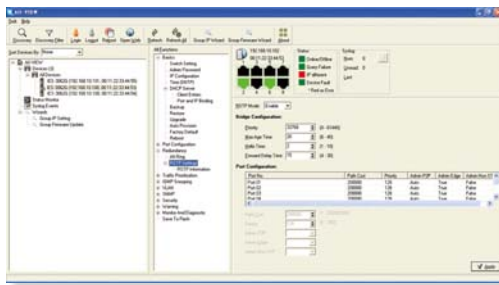

Monitoring and Configuration interface

## Dimensions

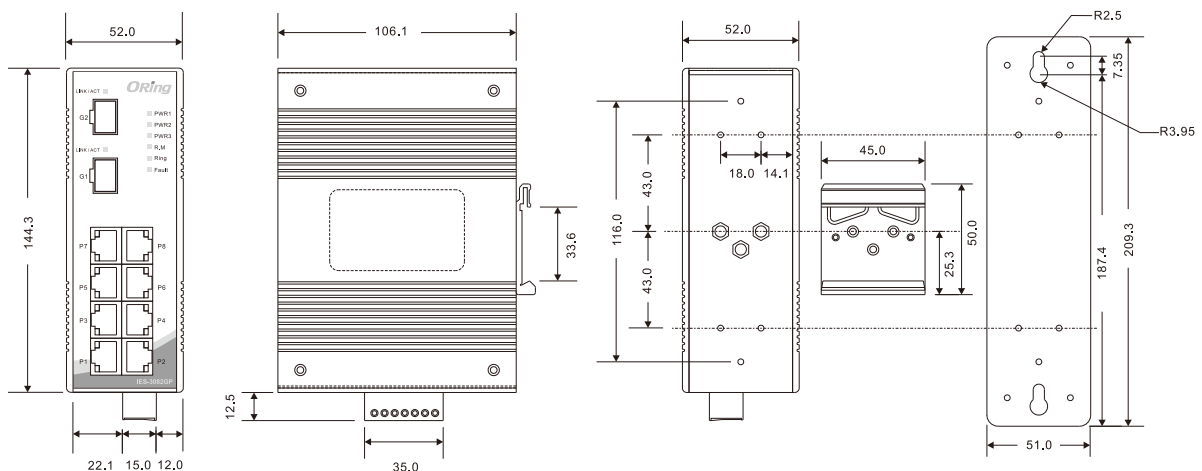

(Unit=mm)

## Specifications

ORing Switch Model	IES-3082GP
<b>Physical Ports</b>	
10/100Base-T(X) Ports in RJ45 Auto MDI/MDIX	8
100/1000Base-X SFP Port	2
<b>Technology</b>	
Ethernet Standards	IEEE 802.3 for 10Base-T IEEE 802.3u for 100Base-TX and 100Base-FX IEEE 802.3z for 1000Base-X IEEE 802.3x for Flow control IEEE 802.3ad for LACP (Link Aggregation Control Protocol) IEEE 802.1D for STP (Spanning Tree Protocol) IEEE 802.1p for COS (Class of Service) IEEE 802.1Q for VLAN Tagging IEEE 802.1w for RSTP (Rapid Spanning Tree Protocol) IEEE 802.1s for MSTP (Multiple Spanning Tree Protocol) IEEE 802.1X for Authentication IEEE 802.1AB for LLDP (Link Layer Discovery Protocol)
MAC Table	8192 MAC addresses
Priority Queues	4
Processing	Store-and-Forward
Switch Properties	Switching latency : 7 $\mu$ s Switching bandwidth : 5.6Gbps Max. Number of Available VLANs : 4096 IGMP multicast groups : 1024 Port rate limiting : User Define
Security Features	Enable/disable ports, MAC based port security Port based network access control (802.1x) VLAN (802.1Q) to segregate and secure network traffic Supports Q-in-Q VLAN for performance & security to expand the VLAN space Radius centralized password management SNMP v1/v2c/v3 encrypted authentication and access security
Software Features	STP/RSTP/MSTP (IEEE 802.1D/w/s) Redundant Ring (O-Ring) with recovery time less than 10ms over 250 units TOS/Diffserv supported Quality of Service (802.1p) for real-time traffic VLAN (802.1Q) with VLAN tagging and GVRP supported IGMP v2/v3 (IGMP snooping support) for multicast filtering Port configuration, status, statistics, monitoring, security SNTP for synchronizing of clocks over network Support <b>PTP Client</b> (Precision Time Protocol) clock synchronization DHCP Server / Client support Port Trunk support MVR (Multicast VLAN Registration) support
Network Redundancy	O-Ring Open-Ring O-RSTP STP RSTP MSTP
Warning / Monitoring System	Relay output for fault event alarming Syslog server / client to record and view events Include SMTP for event warning notification via email Event selection support
RS-232 Serial Console Port	RS-232 in RJ45 connector with console cable. Baud rate setting: 9600bps, 8, N, 1
<b>LED Indicators</b>	
Power Indicator	Green : Power LED x 3
R.M. Indicator	Green : Indicates that the system is operating in O-Ring Master mode
O-Ring Indicator	Green : Indicates that the system is operating in O-Ring mode
Fault Indicator	Amber : Indicates unexpected events occurred
10/100Base-T(X) RJ45 Port Indicator	Green for port Link/Act. Amber for Duplex/Collision
100/1000Base-X SFP Port Indicator	Green for port Link/Act.

Fault Contact	
Relay	Relay output to carry capacity of 1A at 24VDC
Power	
Redundant Input Power	Triple DC inputs. 12~48VDC on 7-pin terminal block, 12~45VDC on power jack
Power Consumption (Typ.)	9 Watts
Overload Current Protection	Present
Reverse Polarity Protection	Present on terminal block
Physical Characteristics	
Enclosure	IP-30
Dimensions (W x D x H)	52(W)x106.1(D)x144.3(H) mm (2.05 x 4.18 x 5.68 inch.)
Weight (g)	730 g
Environmental	
Storage Temperature	-40 to 85°C (-40 to 185°F)
Operating Temperature	-40 to 70°C (-40 to 158°F)
Operating Humidity	5% to 95% Non-condensing
Regulatory Approvals	
EMI	FCC Part 15, CISPR (EN55022) class A
EMS	EN61000-4-2 (ESD), EN61000-4-3 (RS), EN61000-4-4 (EFT), EN61000-4-5 (Surge), EN61000-4-6 (CS), EN61000-4-8, EN61000-4-11
Shock	IEC60068-2-27
Free Fall	IEC60068-2-32
Vibration	IEC60068-2-6
Safety	EN60950-1
MTBF (Hours) (MIL-HDBK-217F2, GB, GC, 25°C)	294,689
Warranty	5 years

### Ordering Information

IES-3 **AA** **B** **CC**

Code efnition	10/100Base-T(X) Port Number	Additional Port Number	Additional Port Type
<b>Option</b>	- <b>8</b> : 8 ports	- <b>2</b> : 2 ports	- <b>GP</b> : 100/1000Base-X SFP port

Available Model	Model Name	Description
	IES-3082GP	Industrial 10-port managed Ethernet switch with 8x10/100Base-T(X) and 2x100/1000Base-X, SFP socket

**Packing List**

- IES-3082GP
- DIN-Rail Kit
- Wall-mount Kit
- Console Cable
- ORing Tool CD
- Quick Installation Guide

**Optional Accessories (Can be purchased separately)**

- Open-Vision M500, Powerful Network Management Windows Utility Suite, 500 IP devices
- SFP100 series, 100Mbps SFP optical transceiver
- SFP1G series, 1Gbps SFP optical transceiver
- DR-45 series, 45W DIN-Rail power supply
- DR-75 series, 75W DIN-Rail power supply
- DR-120 series, 120W DIN-Rail power supply
- PAA-121000, 12VDC/1000mA 12W Power Adapter with universal 100 to 240VAC input, US plug
- PAE-121000, 12VDC/1000mA 12W Power Adapter with universal 100 to 240VAC input, EU plug

- Company Information
- 2011 Product Overview
- Vertical Market Applications
- Industrial Ethernet Switch**
- Industrial Media Converter
- Industrial Device Server
- Industrial Wireless Access Point
- Industrial Cellular VPN Router
- Industrial USB-Over-IP Server
- Accessories
- Network Management Utility